



GEARBOX APPLICATION FORM

COMPANY:

WEBSITE:

CONTACT:

POSITION:

EMAIL:

ADDRESS:

MOTOR SPECIFICATION

D2(OUTPUT SHAFT DIA.)=

KEYWAY(WIDTH)=

D3(OUTPUT PILOT)=

D1(OUTPUT BCD)=

L1(SHAFT OVERALL LENGTH)=

L2(PILOT THICKNESS)=

D4(BOLT DIMENSION)=

MOTOR BRAND:

MODEL NUMBER:

DEFINED SPEED:

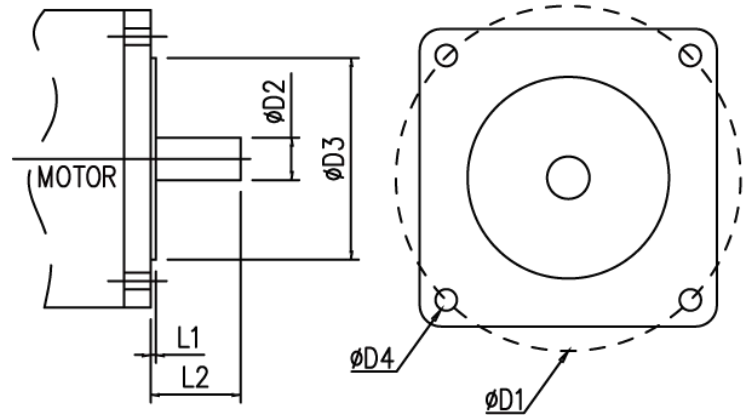

MAX. OUTPUT SPEED:

DEFINED TORQUE:

POWER CAPACITY:

GEARBOX SPECIFICATION

TYPE OF PLANETARY GEARBOX

REDUCTION RATIO

QUANTITY

WRITE YOUR COMMENT OR INFORMATION HERE: